

## SG Three-column Manual Bottom Discharge Scraper Centrifuges



The SG three-column manual bottom discharge scraper centrifuges have nearly the same applications with SGZ three-column automatic bottom discharge scraper centrifuges. However, this vertical scraper centrifuge is highly distinguished by its features.

### **Main Features of SG Scraper Centrifuge**

1. Feeding can be done at medium speed. Manual scraping speed can be adjusted in accordance with filtration cake. Our chemical separation machine is particularly applicable for hard filtration cake.
2. Flexible adjustments are allowed for feeding, primary filtration, washing, fine filtration and discharge, whereby to cater to various substances and separation requirements.
3. As for treatment of loose materials, our pharmaceutical separation machine is compatible with variable frequency drive to achieve stable start-up and adjustable centrifuge force.
4. This liquid clarifying device is endowed with relatively enclosed structure.
5. Scraper movement is mechanically controlled to ensure safety and reliability. In order for more safety, we provide optional rotation speed detection, over-vibration protection, motor overload and overheat protection.

### **Main Application of SG Scraper Centrifuge**

Our chemical separation equipment is the proven solution for treatment of plaster, ammonium sulfate, mirabilite, ferric sulfate, copper sulfate, nickel sulfate, potassium chloride, acetic acid, borax, soda, rubber additive, dyestuff, starch, sugar refining, vitamin, antibiotics, herbicide, vermifuge, copper, zinc, aluminum, anhydrite, metal refining, pure water sludge and sewage sludge.

This pharmaceutical separation equipment also is well-suited for all kinds of medicines.

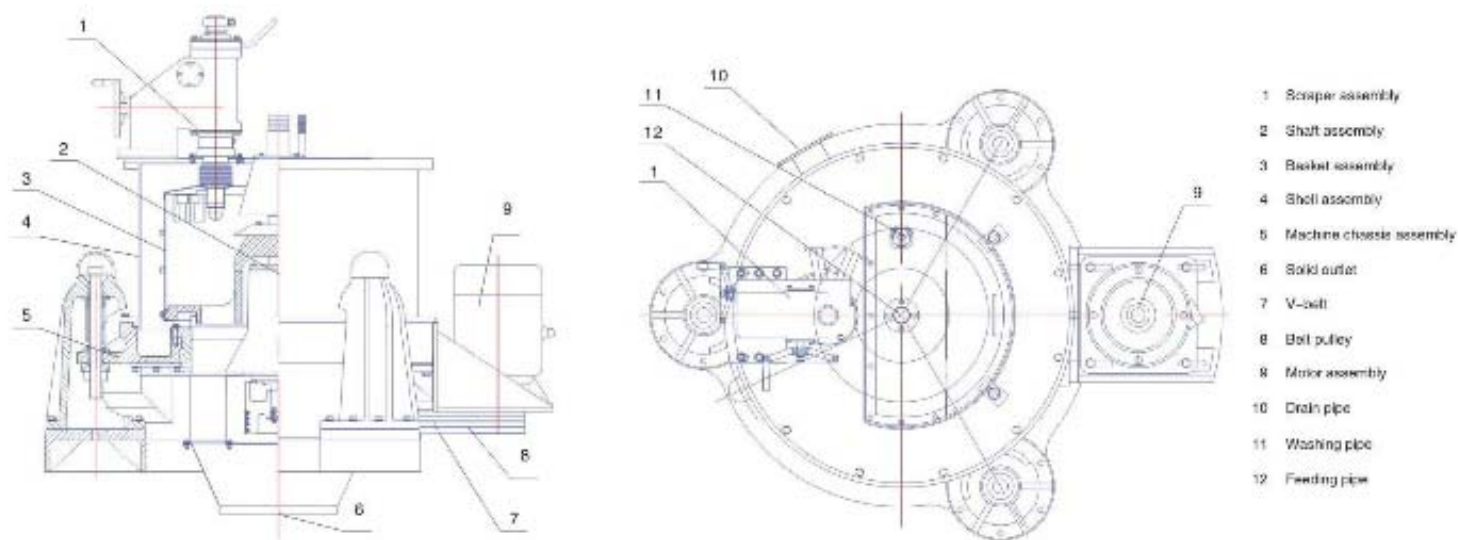

### Note on Configuration of SG Scraper Centrifuge

During order making, special attention should be paid on specific requirements of material, feeding method, explosion-proof, surface finish and electrical component brands, etc.

### Technical Parameter of SG Scraper Centrifuge

Item	Model		
	<a href="#"><u>SG800</u></a>	<a href="#"><u>SG1000</u></a>	<a href="#"><u>SG1250</u></a>
Basket Dia. (mm)	800	1000	1250
Basket Volume (L)	100	140	280
Max. Load (kg)	135	210	420
Max. Speed (rpm)	1200	1000	900
Centrifugal Force	645	560	565
Motor Power (kW)	7.5	11	18.5
Dimension (L×W×H) (mm)	1900×2150×1730	2150×1750×2200	2500×2000×2500
Weight (kg)	2300	3500	4500